



IoT based- Advanced Weather Monitoring System

Pranavi Yadav, Nimish Nigam, Ranjeeta Yadav and
Sanjay Kr. Singh

EasyChair preprints are intended for rapid dissemination of research results and are integrated with the rest of EasyChair.

June 9, 2020

IoT based- Advanced Weather Monitoring System

Pranavi Yadav
Department of ECE
ABES Engineering College, Ghaziabad,
Uttar Pradesh – 201009, India
pranavi129@gmail.com

Ranjeeta Yadav
Department of ECE
ABES Engineering College, Ghaziabad,
Uttar Pradesh – 201009, India
ranjeeta.yadav@abes.ac.in

Nimish Nigam
Department of ECE
ABES Engineering College, Ghaziabad,
Uttar Pradesh – 201009, India
nimish.16bec1165@abes.ac.in

Sanjay Kr. Singh
Department of ECE
ABES Engineering College, Ghaziabad,
Uttar Pradesh – 201009, India
sanjaysinghraj4@gmail.com

Abstract—The proposed system is a progressive solution for weather monitoring at a particular place and make the data available over the internet. The system makes use of the cutting-edge technology Internet of Things (IoT) which aids to connect the embedded system to a network and also to the devices for their operation. The designed system monitors the environmental parameters such as wind speed, temperature and humidity followed by generating real-time data which can be processed and saved on to a cloud. This data can then be viewed in an application so that necessary and timely actions can be taken. The system makes use of sensors, motor and other electronic components for the monitoring of weather parameters.

Keywords— *Arduino IDE, Cloud, IoT, Real-Time monitoring, Smart Environment Monitoring, ThingSpeak and Wireless Sensor Network*

I. INTRODUCTION

Internet of Things (IoT) is one of the many contemporary technologies which has revolutionized the world and is continuing to do so. It has enabled us to monitor and control various electronic appliances remotely with the use of sensor network having the ability of sensing, processing and transmitting the data to a cloud. The cloud is a service providing the capability of storage, complex computation and produce the information in a more convenient form. From the cloud this information can be made available through various user-friendly interfaces such as web or mobile applications, depending upon their appropriateness and requirements [1]. Internet is the heart in this transformation playing a vital role in

productive, reliable and prompt communication of data from devices to the cloud and vice-versa.

With the changing times and technology human needs are also changing. This creates a need for developing smart systems which are able to sense the changes in the environment and thus control the connected devices. Sensor devices are planted at different locations in order to gather the data as and when it senses a change in the area of interest [2]. An environment accoutered with a combination of sensor devices, microcontroller and a software application capable of notifying and self-monitoring the environment then it is often referred to as a smart environment [3]. In such kind of environments, the “things” have the ability of sensing changes in temperature, pressure, humidity, carbon levels, noise, etc. The aforesaid system is an example of embedded system which has a hardware part comprising of all the sensors and electronic components and a firmware written for it. This embedded system enables the user to remotely control its appliances through wireless communication [11]. Integration of such intelligent systems in human life has made its life a lot more effortless and interactive.

II. LITERATURE REVIEW

In today’s world many weather and health monitoring systems are designed by engineers making use of various technologies. Meteorological Departments of various countries and states are still using age old technology or does not have an accurate means to monitor weather parameters resulting in situations such as loss of life, crop failure, damage to

property and food shortages in case of natural disasters. Some of them are mentioned below along with their references:

A. Manual weather monitoring system

Many weather stations still work using the age-old analog technology for weather forecasting and observations [3]. They deploy multiple instruments such as thermometers for temperature, barometers for atmospheric pressure, wind vanes, rain gauge for precipitation etc. to observe changes in the weather conditions [7]. Majority of these instruments are based on simple applications of analog technology. Their observations are later manually recorded and stored [10]. The acquired information is then sent to the news reporting stations, channels and radio for reporting of weather conditions.

Limitations:

1. Such weather monitoring stations consist of obsolete technology which are not in much use today. Also uses heavy machinery consisting of various moving parts that demand regular maintenance and need to be replaced frequently.
2. Power consumption is another issue that poses a limitation as the instruments are usually located far from main power supply, further adding to its cost.
3. Usage of thermometers for measuring temperature; however accurate is still infrequent and periodically requires manual checking of any change in temperature.
4. Manual transfer of data collected is required to a laptop or PC from the logger through a cable.
5. Use of enormous and heavy instruments demands for a huge space and poses difficulty of installation in far-away places.
6. Instruments which are incredibly expensive further scales up the sky-high cost of maintenance and installation.
7. Warnings issued are often delayed due to slackened analog system leading to loss of lives and property.

B. Weather monitoring using master slave communication

In the preceding research [4], a microcontroller based single master and multi slave communication is developed. But the microcontroller still

communicates through unicast communication, i.e. the master can give commands to only one slave at a time arranged in a star topology in a network. The slave with the corresponding address will respond and function according to the master's commands [13]. Along with the master-slave configuration, Modbus Protocol is used for data communication between different devices.

Limitations:

1. In the above systems, communications are between a single master and a single slave in a single master-multi slave configuration [18].
2. Masters can give orders to only one slave at a Time.
3. Slaves can communicate only with the master and not with other slaves in the network.

III. PROPOSED SYSTEM

The proposed system is a leading solution for weather monitoring that incorporates IoT, making the real time data easily available on a user friendly interface which the consumer can access through a thin client like a web browser or a mobile application. Thus making it convenient alternative for the user to directly check the figures and weather conditions of its area online beforehand without the need of a weather forecasting agency. The system also an attractive feature of push notifications on the client's mobile in case the weather conditions worsens, which can alert the consumer to take necessary preventive measures in time.

It has further advantages of:

- Inexpensive
- Installation is not so complex
- Requires less maintenance
- Energy efficient, can be operated on solar energy also.

System monitors change in weather conditions such as wind speed, temperature and humidity. Followed by provision of live reporting of the weather stats over a customized webpage and/or through a mobile application.

The system deals with monitoring weather and climate changes like:

1. Temperature, humidity by using the DHT 22 sensor
2. Wind speed using a DC motor with a fan.

IV. SYSTEM ARCHITECTURE

The main processing unit in the implemented system consists of a microcontroller ATmega 328 which is basically a mini computer. All the sensors and the modules are to be connected to this microcontroller [5]. This minicomputer can then fetch the data from the sensors, for further processing and analysis. The processed data is then updated on the local network via the Wi-Fi microchip ESP 8266 connected to it.

BLOCK DIAGRAM:

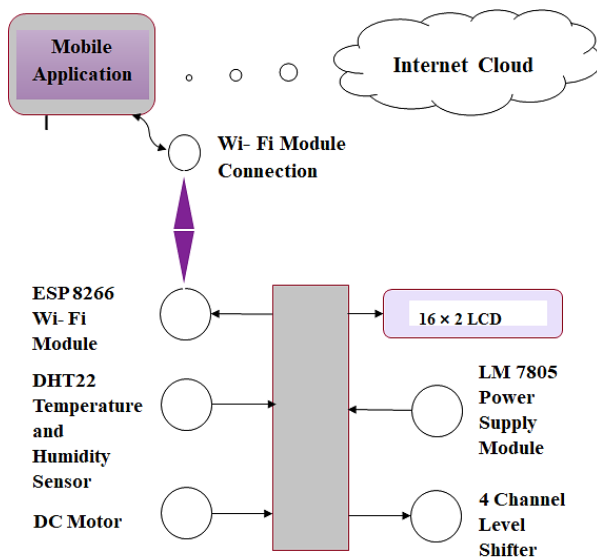

Fig.1 Block Diagram of the Proposed System

V. SOFTWARE IMPLEMENTATION

The code written for the hardware design plays a crucial role in its working. This code is referred to as a firmware once it is burnt in the microcontroller. There are two stages in the development of our software: initialization and simulation of hardware. Lastly, transmitting the data to a mobile application for user interface.

A. Firmware for Initialization and Simulation of Hardware:

Arduino IDE: It is an open-source integrated development environment to program the microcontroller. The IDE is platform independent i.e.

can be run on Windows, MAC OS or Linux [6]. It can be used with any Arduino board. Once the code is written and tested it can be used to retrieve data from the sensors and transmission on to a cloud. The electronic components are integrated with the controller after their individual testing [12]. Now to make the Wi-Fi module work as client it has to be initialized by sending AT commands in a defined pattern. Finally, DHT 22 a digital temperature and humidity sensor provides real-time readings for both the parameters simultaneously. We use MATLAB analytics service of ThingSpeak to visualize the live data stream on the mobile app, once the sensor data is fetched and processed by the microcontroller and uploaded onto the cloud [15]. ThingSpeak provides quick visualization of the real-time data transmitted by our embedded system in a presentable form.

B. Mobile Application:

Blynk: is the most popular application designed for IoT. It can store, visualize and display sensor data. One can also control hardware devices from remote locations. It is a digital dashboard with easy to use widgets, pin manipulation without the need of writing a code, makes device to device communication possible, send emails, tweets and also push notification.

VI. COMPARISON

IoT technology is deployed in many ways so no single network solution is right. It depends on the situation and where the devices are located. Some of the factors affecting the selection of the type of network are network range, network bandwidth, power usage, interoperability, intermittent connectivity and security.

A. Wired Technology

1. Cost: Wired connections are more expensive than wireless due to the cost of the wire, labor costs for installation.
2. Mobility: Wired networks would need to be buried in walls, floors and ceilings in order to reach the sensors that need to be connected to it.
3. Scalability: Building and extending wired networks requires planning and a budget to construct it. Wired systems need hardware to be purchased, installed and configured before it can be fully operational.

B. Wireless IoT Implementation

1. Scalable: Wireless networks do not require any hardware installations. They typically involve configurations and can be up and running in a short time.
2. Cost-Effective: Due to advancement in wireless technology as well as the number of manufacturers, the cost of the wireless has been decreasing over the last few years.
3. As most wired networks tend to be bulky and expensive, Wireless IoT implementations are the common solution.

VII. CONCLUSIONS

In the course, our objective is to come up with a highly accurate and an inexpensive automated weather monitoring system. The embedded system proposed would be capable of observing the changes in the environmental parameters and periodically update the consumer over an app thus making it smart and interactive. The smart system will also be able to generate short term push notifications when the figures cross a warning limit. The sensors are to be deployed in the environment which needs to be monitored in order to collect the data for analysis. The information after processing of the collected data can be accessed by the consumer through Wi-Fi.

VIII. FUTURE POTENTIAL

- Few more sensors can be integrated and connect the system to the satellite making it a global feature.
- To implement the system for a town or a village, a Wide Area Network can be brought into use [7].
- There is a great potential of this real time system in the navigation of aircrafts, military and defense as well [9].
- To provide better precautionary measures and development of medication, it can be implemented in medical institutes for the research & study of the harmful effects of changing weather conditions on health [12].
- It can be deployed in farms to alert the farmers of high speeds, humidity and temperature conditions to cover its harvested crops or regulate their irrigation patterns respectively.

REFERENCES

- [1] D. K. Singh, H. Jerath and P. Raja, "Low Cost IoT Enabled Weather Station," 2020 International Conference on Computation, Automation and Knowledge Management (ICCAKM), Dubai, United Arab Emirates, 2020, pp. 31-37, doi: 10.1109/ICCAKM46823.2020.9051454.
- [2] P. Kapoor and F. A. Barbhuiya, "Cloud Based Weather Station using IoT Devices," TENCON 2019 - 2019 IEEE Region 10 Conference (TENCON), Kochi, India, 2019, pp. 2357-2362, doi: 10.1109/TENCON.2019.8929528.
- [3] L. Kamelia, Y. S. Nugraha, M. R. Effendi and T. Priatna, "The IoT-Based Monitoring Systems for Humidity and Soil Acidity Using Wireless Communication," 2019 IEEE 5th International Conference on Wireless and Telematics (ICWT), Yogyakarta, Indonesia, 2019, pp. 1-4, doi: 10.1109/ICWT47785.2019.8978243.
- [4] Onkar Amale, Rupali Patil, "IOT Based Rainfall Monitoring System Using WSN Enabled Architecture", IEEE, Conference Paper 2019
- [5] R. Nageswara Rao, B. Sridhar, "IoT based smart crop-field monitoring and automation irrigation system", IEEE, Conference Paper, 2018
- [6] R. Kumar M. Math, Nagaraj V. Dharwadkar, "IoT Based Low-cost Weather Station and Monitoring System for Precision Agriculture in India", IEEE, Conference Paper, 2018
- [7] Petcharat Suriyachai, Jakkapong Pansit, "Effective Utilization of IoT for Low-cost Crop Monitoring and Automation", IEEE, Conference Paper, 2018
- [8] V. Lohchab, M. Kumar, G. Suryan, V. Gautam and R. K. Das, "A Review of IoT based Smart Farm Monitoring," 2018 Second International Conference on Inventive Communication and Computational Technologies (ICICCT), Coimbatore, 2018, pp. 1620-1625, doi: 10.1109/ICICCT.2018.8473337.
- [9] Yashaswi Rahut, Rimsha Afreen, Divya Kamini, "Smart weather monitoring and real time alert system using IoT", IRJET, Vol 5, Issue:10, Oct 2018
- [10] G. Sahitya, N. Balaji, C. D. Naidu and S. Abinaya, "Designing a Wireless Sensor Network for Precision Agriculture Using Zigbee," 2017 IEEE 7th International Advance Computing Conference (IACC), Hyderabad, 2017, pp. 287-291, doi: 10.1109/IACC.2017.0069.
- [11] S. Halder, G Sivakumar, "Embedded based remote monitoring station for live streaming of temperature and humidity", IEEE, Conference Paper, 2017
- [12] Hakan Ucgun, Zeynep Kubra Kaplan, "Arduino based weather forecasting station", IEEE, Conference Paper, 2017
- [13] Ayyappadas R, (Communication Systems), A.K.Kavitha, Dr.S.MaryPraveena, Dr.R.M.S.Parvathi, "Design and Implementation of Weather Monitoring System using Wireless Communication", International Journal of Advanced Information in Engineering Technology (IJAIET) ISSN: 2454-6933 Vol.4, No.5, May 2017
- [14] Chen Xiaojun, Liu Xianpeng, Xu Peng, "IOT-based air pollution monitoring and forecasting system", IEEE, Conference Paper, 2015
- [15] Y. Mittal, A. Mittal, D. Bhateja, K. Parmaar, V.K. Mittal, "Correlation among environmental parameters using an online Smart Weather Station System", IEEE, Conference Paper, 2015

- [16] P.Susmitha, G.Sowmyabala, "Design and Implementation of Weather Monitoring and Controlling System", International Journal of Computer Applications Volume 3, issue 2, March-April, 2015
- [17] P. H. Khotimah, D. Krisnandi and B. Sugiarto, "Design and implementation of Remote Terminal Unit on Mini Monitoring Weather Station Based on Microcontroller," 2011 6th International Conference on Telecommunication Systems, Services, and Applications (TSSA), Bali, 2011, pp. 186-190, doi: 10.1109/TSSA.2011.6095431.
- [18] P. Zhou and X. Ling, "HCI-based bluetooth master-slave monitoring system design," International Conference on Computational Problem-Solving, Lijiang, 2010, pp. 406-409.