



Kalpa Publications in Engineering

Volume 1, 2017, Pages 470–477

ICRISET2017. International Conference on Research and Innovations in Science, Engineering & Technology. Selected Papers in Engineering



Compact Switched Mode Power Supply for Medium-Voltage Drives

Modi Ankit B.
Assistant Professor
Dept. of Electrical Engg.
Sankalchand Patel College
of Engineering, Visnagar
11meep04@nirmauni.ac.in

P. N. Tekwani
(Senior Member - IEEE)
Professor and Head
Dept. of Electrical Engg.
Institute of Technology
Nirma University, Ahmedabad
pn.tekwani@nirmauni.ac.in

Vinod Patel
DGM (R&D)
AMTECH Electronics(I) Ltd.
Gandhinagar
vinodp@amtechelectronics.com

Abstract

A switched mode power supply (SMPS) with multiple outputs has been developed which satisfies the need of isolation of control circuit power supply and driver section power supply for a medium-voltage electrical drive. It means that there is no need of extra components for isolation. For this SMPS, fly-back converter topology along with current mode control method is selected and its performance is observed for line, load as well as cross regulation with other tests. This SMPS generates multiple outputs of +5 V, +24 V, +/- 15 V and five +24 V isolated output voltages.

1 Introduction

Now-a-days, SMPS have replaced Linear Regulated Power Supplies in almost all of the consumer electronic applications due to their advantages like higher efficiency, better output voltage regulation, compact size with their main advantage of capability to provide isolation between multiple outputs. [1-2] Electronic equipments and Electrical Drives requires multiple outputs and in addition it might be required that all the outputs need to be regulated and isolated from each other. SMPS typically uses switching frequencies of the order of a few kHz to few tens of kHz and from the studies it has been found that as the switching frequency increases, transformer size reduces drastically. In some of the applications, for example, Personal Computers and Embedded System based control applications, it has been observed that different output voltage levels such as ± 5 V, +3.3 V and ± 12 V are used with isolation. In some of the Electrical Drives, it has been observed that two different SMPS units are used to Energize Control Section and Driver Section. If there are 'n' outputs in an SMPS, it normally uses 'n+1' dc-dc converters to obtain individual control of all the outputs. [3-4] This SMPS generates

10 outputs from which outputs +5 V, +24 V, +/-15 V for control circuitry, and four +24 V isolated for driver section and +24 V for fan power supply. Different winding arrangement and their effects of various magnetic structures of high frequency transformers on cross regulation and the comparison of transformer winding arrangements that affect the cross regulation in a multiple-output flyback converter are presented in [5] and [6]. In [7], three methods of transformer winding arrangements are presented in comparison. Each winding arrangement has reasonably performed in such a way to control leakage inductance in order to improve cross regulation in a multiple output flyback converter. From the experimental results, it was concluded in paper [7] that amongst all the three methods, sandwich type winding is having a very tight coupling between windings and have better cross regulation than other two methods.

2 SYSTEM WORKING

A fly-back converter is basically an isolated version of the buck-boost converter in which the inductor has been replaced by a fly-back transformer. When the switch is turned on, energy is stored in Fly-back Transformer from an input source. When the switch turns off, the transformer voltage reverses, forward-biasing the output side diodes and delivering the stored energy to the outputs. With a fly-back topology, an output can be positive or negative defined by a transformer polarity dot. This fly-back transformer is basically a coupled inductor which may have more than one secondary. The input dc source V_s and switch S are connected in series with the primary transformer winding. The diode D and the R-C output circuit are connected in series with the secondary of the fly-back transformer. A simple block diagram showing components used in fly-back converter is shown in figure 1.

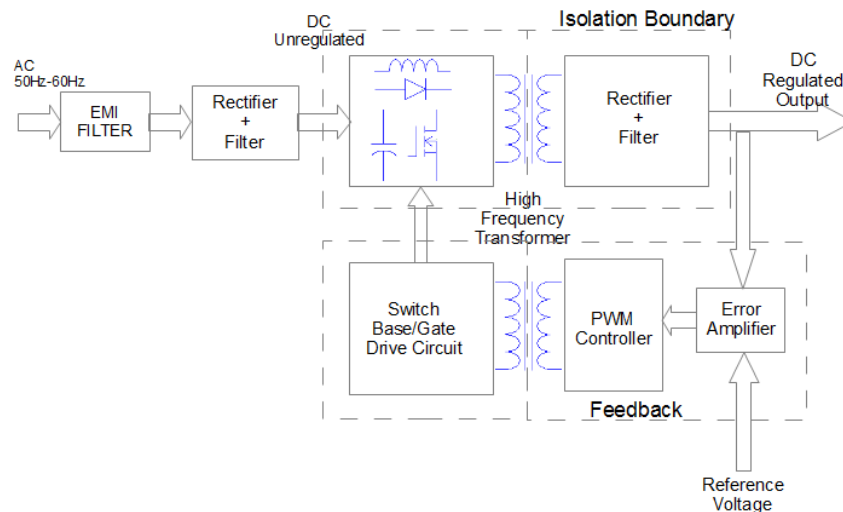

Figure 1: Block Diagram of Fly-back Converter

Depending on the switching, there may be two modes of operation; Continuous Conduction Mode (CCM) and Dis-continuous Conduction Mode (DCM). In CCM, the current does not reduce to zero before the switch is turned on, and hence core flux does not gets reset to zero. So, in CCM, not all the stored energy is transferred to the secondary side, and hence this method is also called Incomplete Energy Transfer Mode. Figure 2 and Figure 3 shows CCM operation and current waveforms respectively.

While in DCM, the current falls to zero before the switch is turned on again and flux core resets to zero. So, in DCM, all the stored energy is transferred to the secondary side. Hence, this method is also called Complete Energy Transfer Mode. Figure 4 and Figure 5 shows DCM operation and current waveforms respectively.

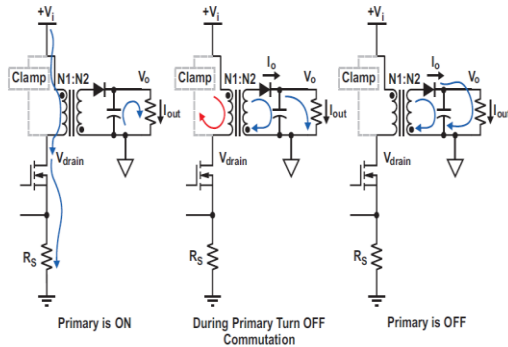

Figure 2: CCM operating modes

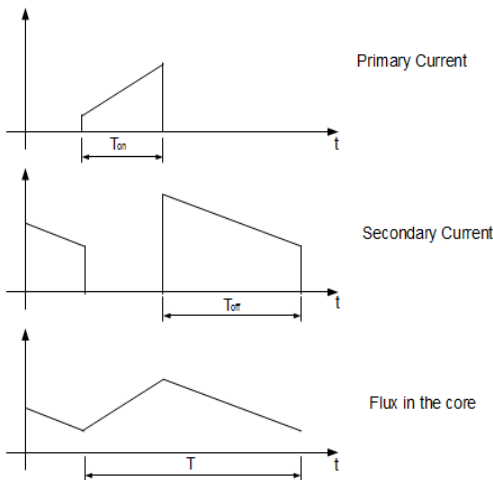

Figure 5: CCM waveforms

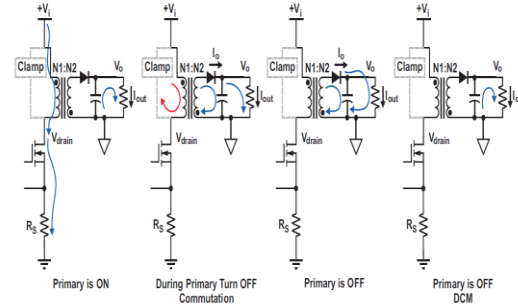

Figure 3: DCM operating modes

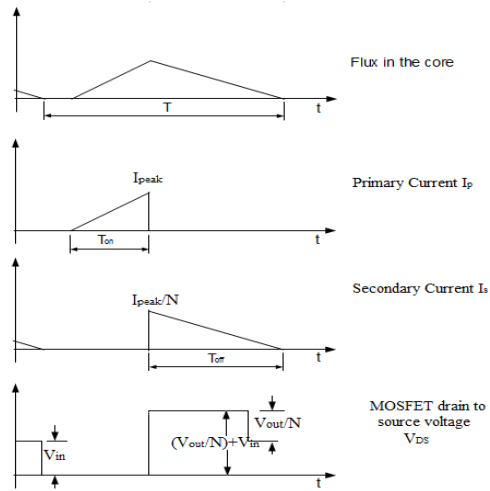

Figure 4: DCM waveforms

The table below gives comparison between CCM and DCM.

Table 1: Comparison CCM & DCM

Parameters	CCM	DCM
Inductance	High	Less
Inductor physical size	Large	Small
Core loss	Small	High $\Delta\phi$ increases core loss
EMI	Low	High
Peak-to-peak current ripple	Less	Twice the average current
Dynamic response	Slow due to high magnetizing inductance	Fast due to low magnetizing inductance
Dynamic cross regulation	poor	good

3 MULTIPLE OUTPUT SMPS DESIGN

SMPS has been developed for multiple outputs with the required output voltage levels even if the power supply is delivering full load over the full range of input voltage. Closed loop control is employed along with Discontinuous Conduction Mode and Current Mode Control. Depending on Output voltage levels and output current requirements, SMPS is rated near about 24 W.

General Specifications:

- Input Voltage Range: 85 VAC to 265 VAC
- Switching Frequency: 50 kHz
- Maximum Duty Cycle: 50 %
- Maximum Output Power: 24 W
- Expected Efficiency: 80 %

Output Specifications :

- Output 1 : +24 V / 285 mA
- Output 2 : +24 V / 130.2 mA
- Output 3 : +15 V / 288 mA
- Output 4 : -15 V / 48 mA
- Output 5 : +5 V / 523.8 mA
- Output 6 to 9 : +24 V / 50 mA
- Auxiliary Winding : +15 V / 70 mA

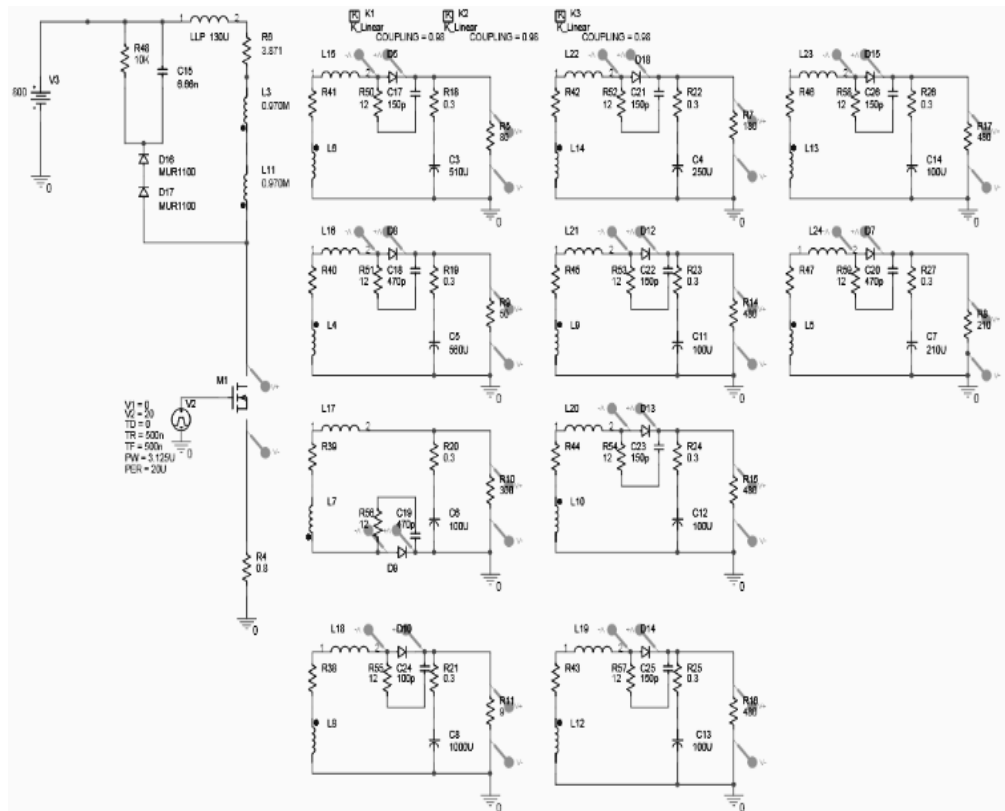

Figure 6: Open loop simulation circuit in PSpice software

Open loop simulation circuit and simulation results are shown in figures 6 and 7, respectively. Figure 7 shows the simulation results of SMPS output voltages at 500 V input voltage and 22% duty cycle of switching pulse.

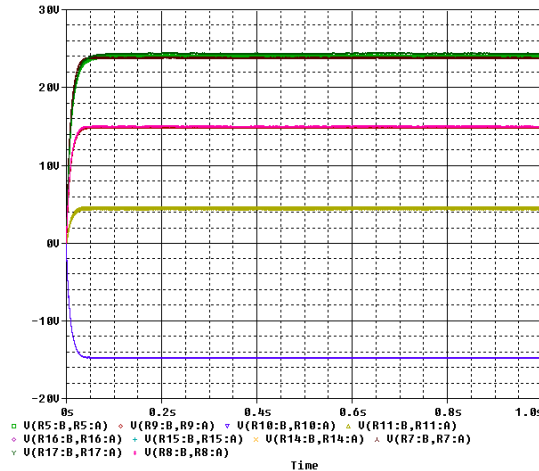

Figure 7: Simulated Output Voltages at $V_{in} = 500\text{ V}$ and 22% duty cycle; X-axis : 1 div = 0.2 sec; Y-axis : 1 div = 10 V

4 EXPERIMENTAL RESULTS

The figures in this section shows hardware results of the developed SMPS. Fig. 8 (a) shows the waveform of duty cycle when maximum input voltage of 500 V DC is given. It can be seen that the duty cycle is 22.7% which is nearly coming near to the simulation results. To measure the current through the primary winding sensing resistor RSENSE is used. Fig. 8 (b) shows the waveform of voltage across RSENSE, which in turn shows the current waveform. Fig. 8 (c) shows the voltage across the switch. From Fig. 8 (d), (e) and (f), it can be seen that the output voltages have ripples less than 1 % with respect to output voltages. Fig. 9 and Fig. 10 shows waveforms at different input voltage levels.

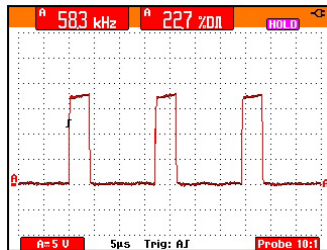

Figure 8 (a)

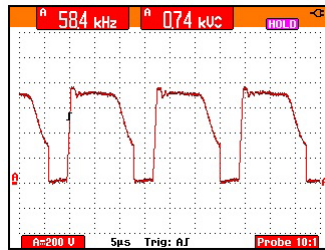

Figure 8 (c)

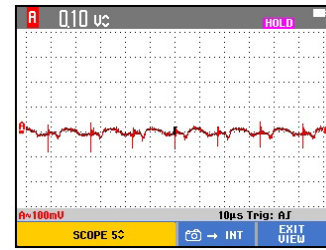

Figure 8 (e)

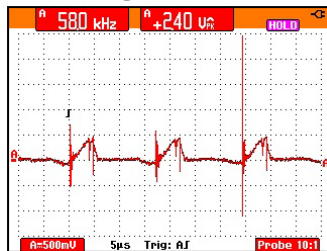

Figure 8 (b)

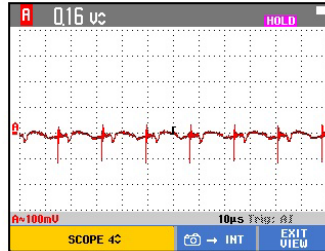

Figure 8 (d)

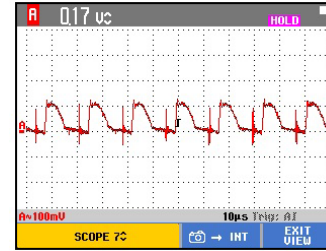

Figure 8 (f)

- Figure 8 (a)** Experimental results of Duty Cycle at 500 V input;
X-axis : 1 div = 5 μ sec; Y-axis : 1 div = 5 V
- Figure 8 (b)** Experimental results of Current from Primary Winding at 500 V input;
X-axis : 1 div = 5 μ sec; Y-axis : 1 div = 500 mV
- Figure 8 (c)** Experimental results of Voltage Spike at 500 V input;
X-axis : 1 div = 5 μ sec; Y-axis : 1 div = 200 V
- Figure 8 (d)** Experimental results of Ripple waveforms in +15 V output voltage;
X-axis : 1 div = 10 μ sec; Y-axis : 1 div = 100 mV
- Figure 8 (e)** Experimental results of Ripple waveforms in +5 V output voltage;
X-axis : 1 div = 10 μ sec; Y-axis : 1 div = 100 mV
- Figure 8 (f)** Experimental results of Ripple waveforms in +24 V output voltage;
X-axis : 1 div = 10 μ sec; Y-axis : 1 div = 100 mV

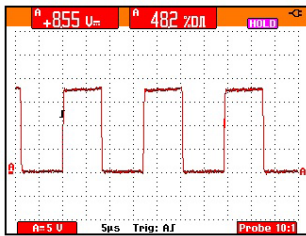

Figure 9 (a)

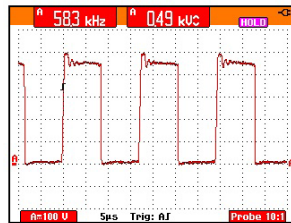

Figure 9 (c)

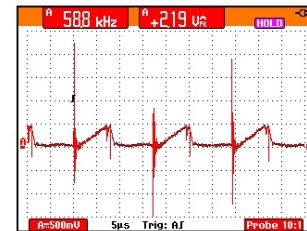

Figure 9 (e)

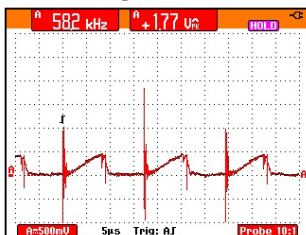

Figure 9 (b)

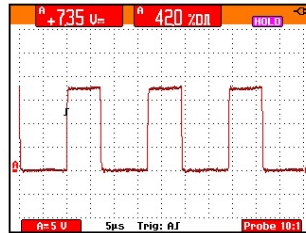

Figure 9 (d)

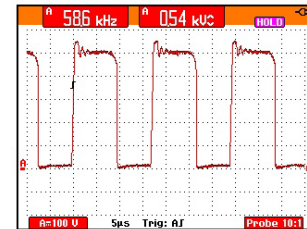

Figure 9 (f)

- Figure 9 (a)** Experimental results of Duty Cycle at 250 V input;
X-axis : 1 div = 5 μ sec; Y-axis : 1 div = 5 V
- Figure 9 (b)** Experimental results of Current from Primary Winding at 250 V input;
X-axis : 1 div = 5 μ sec; Y-axis : 1 div = 500 mV
- Figure 9 (c)** Experimental results of Voltage Spike at 250 V input;
X-axis : 1 div = 5 μ sec; Y-axis : 1 div = 200 V
- Figure 9 (d)** Experimental results of Duty Cycle at 300 V input;
X-axis : 1 div = 5 μ sec; Y-axis : 1 div = 5 V
- Figure 9 (e)** Experimental results of Current from Primary Winding at 300 V input;
X-axis : 1 div = 5 μ sec; Y-axis : 1 div = 500 mV
- Figure 9 (f)** Experimental results of Voltage Spike at 300 V input;
X-axis : 1 div = 5 μ sec; Y-axis : 1 div = 200 V

The output voltages of + 24 V which are isolated from each other are used as supply voltage for driver ICs for IGBTs of the electrical drive. Fig. 10 shows the output waveforms of driver circuitry which is supplied by SMPS. The pulses shown here can directly be given to IGBTs for turning ON and OFF.

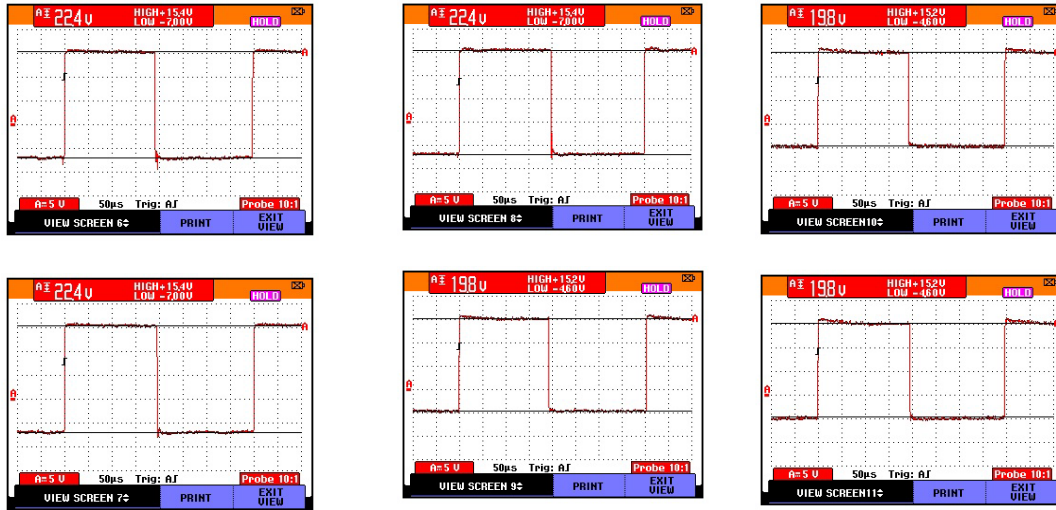

Figure 10 Gate Pulses for Switches: on left side (S1, S3, S5), on right side (S2, S4, S6);
X-axis : 1 div = 50 µsec; Y-axis : 1 div = 5 V

The table given below shows the output voltage for different input DC voltages. The peak current through primary winding and switch, and duty cycle are also tabulated for different input voltages. And Voltage Spike indicated here is described as the voltage appearing across the switch which is the addition of input voltage and voltage across primary winding while the switch is in Off state.

Table 2: Output Voltages with different Input Voltages

Input DC Voltage	250 V	300 V	400 V	500 V	600 V
+ 24 V	23.6	23.3	23.4	23.1	22.96
+ 15 V	14.9	14.8	14.8	14.8	14.65
+ 5 V	5.09	5.08	5.07	5.07	5.072
- 15 V	-15.4	-15.3	-15.3	-15.3	-15.11
+ 24 V (I)	25.1	25	25	24.9	24.7
Top U +ve	16.2	16	16	16	15.88
Top U - ve	-6.88	-6.88	-6.91	-6.89	-6.885
Top V +ve	16.3	16.2	16.1	16.1	15.94
Top V -ve	-6.82	-6.82	-6.86	-6.84	-6.823
Top W +ve	16.5	16.3	16.3	16.3	16.12
Top W - ve	-6.82	-6.83	-6.84	-6.84	-6.83
Bottom +ve	17.7	17.5	17.5	17.5	17.37
Bottom -ve	-5.49	-5.46	-5.46	-5.47	-5.42
Voltage Spike (V)	492	540	630	740	870
Duty Cycle (%)	48.2	42.1	31.4	22.7	17.2
Peak Current (mA)	460	480	500	460	480
Switching Frequency (kHz)	58.3	58.3	58.5	58.3	58.3

5 Conclusion

Flyback converter topology is selected for developing multiple output SMPS for the need of power supply section of a medium-voltage electrical drive. Developed SMPS satisfies the voltage regulation needs of power supply for the application. Developed SMPS is also put to other tests like polarity test, high-voltage test, line regulation, load regulation, cross regulation, heat run test, and short circuit test. The tests are carried out and the results are observed, and are found to be well within the specific limits. Through the practical experimentation, line and load regulation are less than 5 % and cross regulation is less than 3 %.

References

- [1] Abraham I. Pressman, *Switching Power Supply*, 2nd ed., McGraw Hill, New York.
- [2] R. W. Erickson, *Fundamentals of Power Electronics*, Kluwer Academic Publishers, Massachusetts, 1999.
- [3] R. D. Middlebrook and S. Cuk, "Isolation and Multiple Output Extensions of a New Optimum Topology Switching DC-DC Converter" in *Proc. of IEEE PESC 1978*, pp. 256-264.
- [4] C. A. Canesin and I. Barbi, "A unity power multiple Isolated Outputs Switching Mode Power Supply using a single switch" in *Proc. of IEEE APEC '91*, pp. 430-436.
- [5] Pairote Sangampai, Kusumal Chalermyanont, Anuwat Prasertist and Surapon Theinmontri, "The study The effects of High Frequency Transformer Core types for improve cross regulation in Multiple Output Flyback Converters", *PSU-Engineering Conference, Thailand (PECS), May 2007*.
- [6] Pairote Sangampai, Kusumal Chalermyanont, Anuwat Prasertist and Surapon Theinmontri, "The comparative study and Design Guidelines of a High Frequency Transformer for improving Cross Regulation in Multiple-Output Flyback Converters" *ECTI-CON 2007 Mea Fah Luang University Chiang Rai, Thailand*.
- [7] Kusumal Chalermyanont, Pairote Sangampai, Anuwat Prasertist and Surapon Theinmontri, "High Frequency Transformer Designs for improving cross regulation in Multiple-Output Flyback Converters" *Proc. of IEEE PEDS-2007*, pp. 53-56.